

## VE-DF-In-Line Axial Exhaust Fan



- For constant or periodic exhaust ventilation of bathrooms, kitchens and other domestic compartments .
- Used with plastic PVC ducts or flexible ducts.
- Exhaust or supply ventilation, depends on fan installation.
- Case and impeller are made from the high-quality PP plastic, resistant to ultraviolet.
- The motor on sleeve bearings is installed. Does not require additional service.
- The motor is equipped with overheating protection.
- For VE-DF BB - motor on ball bearings with extended operational life (up to 40 000 operating hours) is installed.
- Fans of this series have different diameters of inlet and outlet pipes for the possibility of connection of grill of VE-RPKF series with flange of the corresponding diameter from the air intake side (if the fan is installed directly in the ventilation shati opening or in place of the existing ventilation grill).
- Degree of cover protection of an electric equipment against penetration of solid objects and water - IP24.
- IEC CB EN 60335-2-80 Standart Certified
- 5 Years Guarantee



Fan Color	White
Impeller Material	High Structer ABS Plastic
Body Material	High Structer ABS Plastic
Working Temperature	-20 - +50 °C
Standards	IEC-CB-EN 60335-2-80

Motor Insulation Class	B Class
Motor Bearing System	Sleeve Bearing
Motor Enamelled Wire	100 % Copper
Motor Protection	Over Heating Protection
Motor Brand	VentEurope

### Specifactions

Model	Diameter, mm	Power Watt	Capacity m <sup>3</sup> /h	Pressure Pa	Noise level, db(A)	Current Amper
VE100-DF	100	10	107	46	35	0,06
VE125-DF	125	12	190	56	36	0,07
VE150-DF	150	16	300	65	38	0,07

### Dimensions

Model	d	D	A	E
VE100-DF	100	103	80	98
VE125-DF	125	128	87	123
VE150-DF	150	153	101	148

All dimensions are mm.

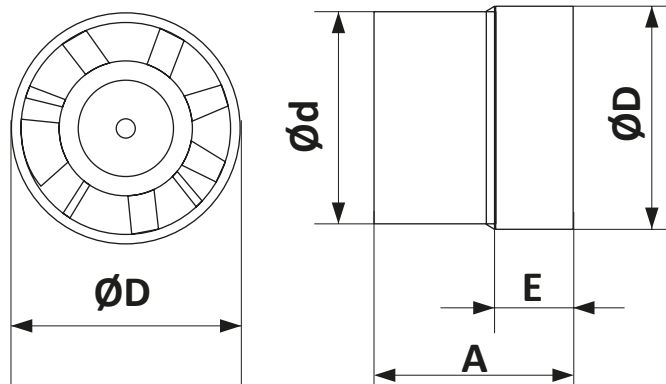

**VE-DF- In-Line Axial Exhaust Fan**

**Diagrams**

**VE-DF-100**

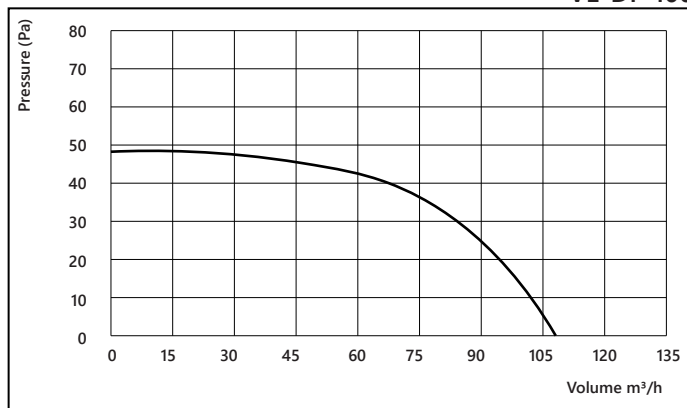

**VE-DF-125**

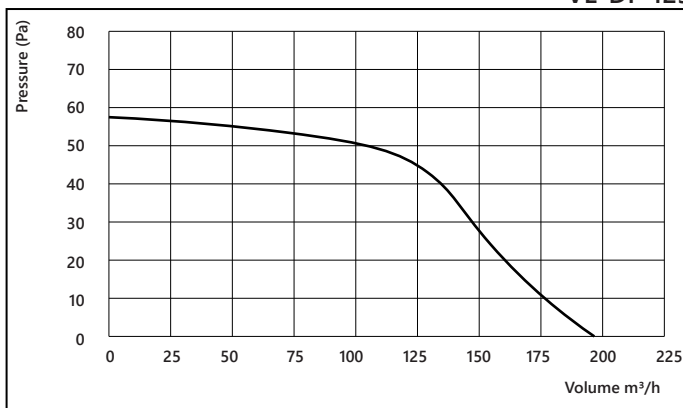

**VE-DF-150**

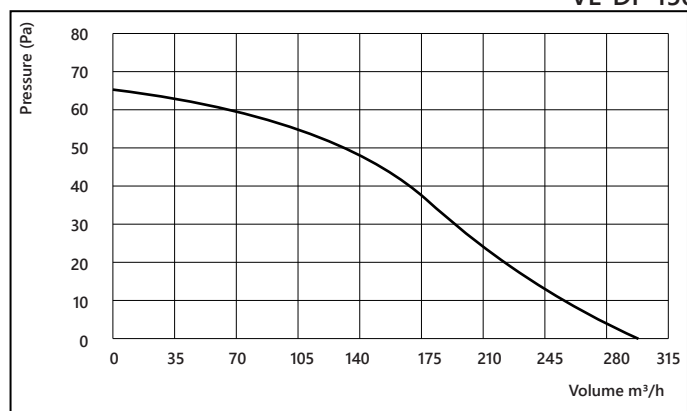

Mounting of the fan with **BB** option in horizontally directed ducts is possible.

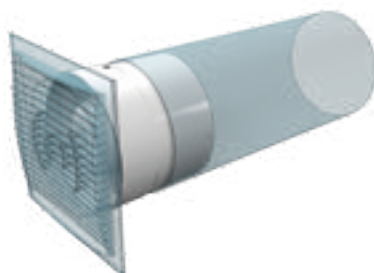

**VE-DF fan mounting with VE-VP air vent and VE-RSF grill**

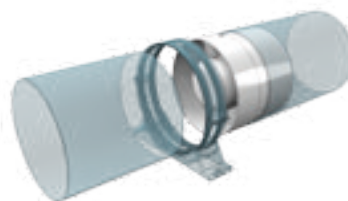

**VE-DF fan mounting with VE-VP air vent and duct bracket DSKP**